

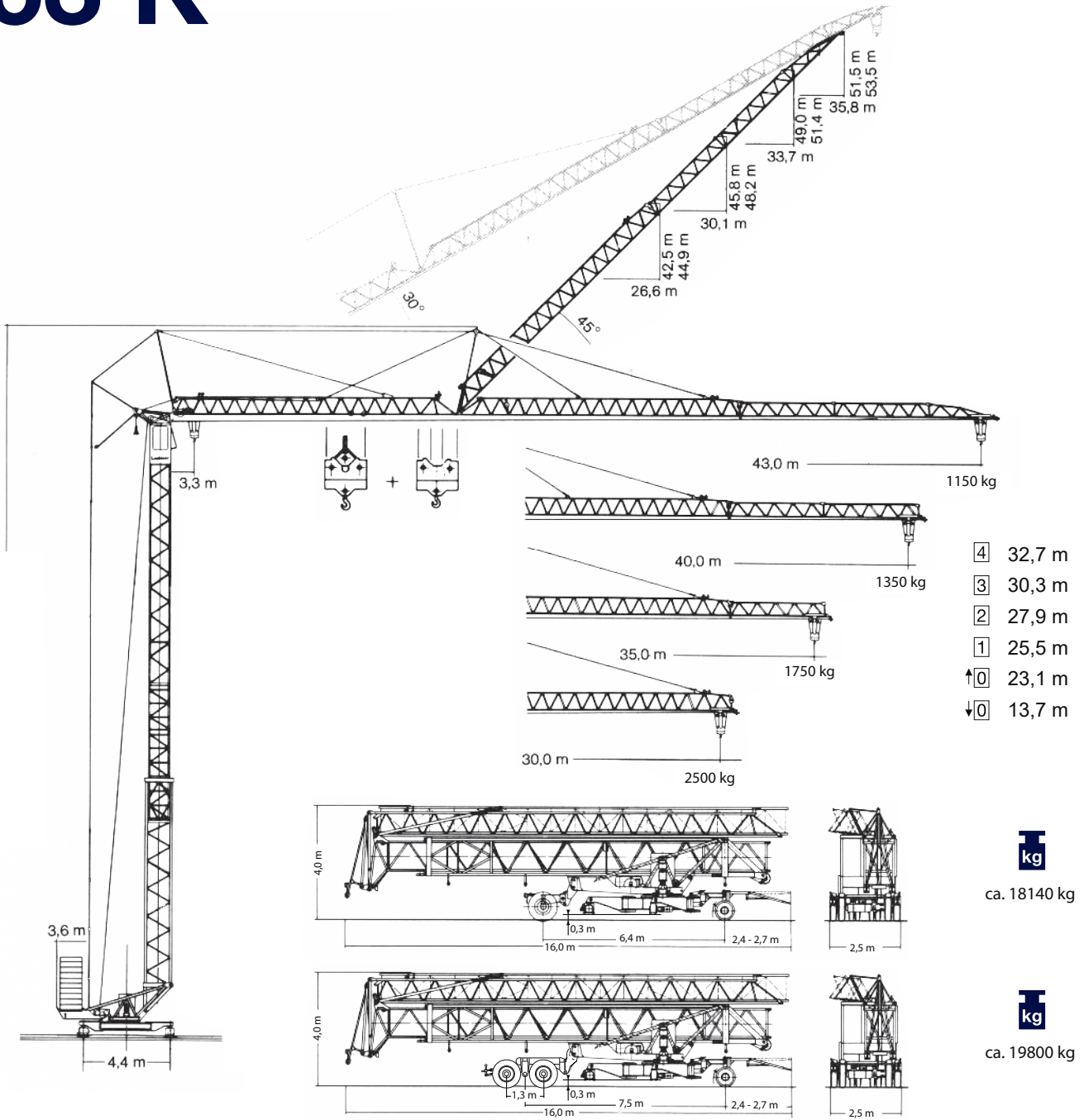







Věžový jeřáb samostavitelný 63 K











protizátěž		váha konstrukce	
	r = 3,6 m		18800 kg
	26000 kg		

LIEBHERR

Vyložení a nosnost

vyložení		m/kg		nosnost																				
m	m/kg			19,0	20,0	22,0	24,0	26,0	28,0	29,0	30,0	31,0	32,0	33,0	34,0	35,0	36,0	37,0	38,0	39,0	40,0	41,0	42,0	43,0
43,0	3,3 – 19,5 3050			3050	2970	2640	2380	2160	1970	1890	1800	1740	1670	1610	1550	1490	1440	1390	1350	1300	1260	1220	1180	1150
40,0	3,3 – 20,6 3050			3050	3050	2810	2530	2300	2100	2010	1900	1850	1780	1720	1650	1590	1540	1490	1440	1390	1350	1300	1260	1220
35,0	3,3 – 21,7 3050			3050	3050	3050	2760	2510	2290	2200	2110	2030	1950	1880	1810	1750								
30,0	3,3 – 25,3 3050			3050	3050	3050	3050	2960	2710	2600	2500													



		m/kg		nosnost																				
m	m/kg			11,0	12,0	14,0	16,0	18,0	20,0	22,0	24,0	26,0	28,0	30,0	32,0	34,0	35,0	37,0	38,0	39,0	40,0	41,0	42,0	43,0
43,0	3,3 – 19,5 3050			6000	5730	4700	3960	3410	3000	2650	2370	2140	1950	1750	1640	1510	1460	1350	1300	1260	1220	1170	1140	1100
40,0	3,3 – 20,6 3050			6000	6000	4970	4190	3620	3170	2810	2520	2280	2070	1900	1750	1610	1550	1440	1390	1340	1300	1260	1220	1180
35,0	3,3 – 21,7 3050			6000	6000	5370	4540	3920	3440	3050	2740	2480	2260	2070	1910	1760	1700							
30,0	3,3 – 25,3 3050			6000	6000	5800	4900	4240	3720	3310	2950	2690	2350	2250										

		m/kg		šikmý výložník 30°																				
m	m/kg			17,0	18,0	19,0	20,0	21,0	22,0	23,0	24,0	25,0	26,3	27,0	28,0	29,0	30,6	32,0	33,0	34,0	34,9	36,0	37,0	37,5
43,0	3,1 – 17,2 3050			3050	2890	2700	2540	2390	2260	2130	2020	1920	1800	1750	1670	1600	1490	1410	1360	1310	1260	1210	1170	1150
40,0	3,1 – 18,1 3050			3050	3050	2880	2700	2540	2400	2270	2160	2050	1900	1860	1780	1710	1590	1510	1450	1400	1350	1300	1260	1220
35,0	3,1 – 19,4 3050			3050	3050	3050	2950	2780	2620	2480	2360	2240	2110	2040	1950	1870	1750							
30,0	3,1 – 22,3 3050			3050	3050	3050	3050	3050	3050	2940	2790	2680	2500											

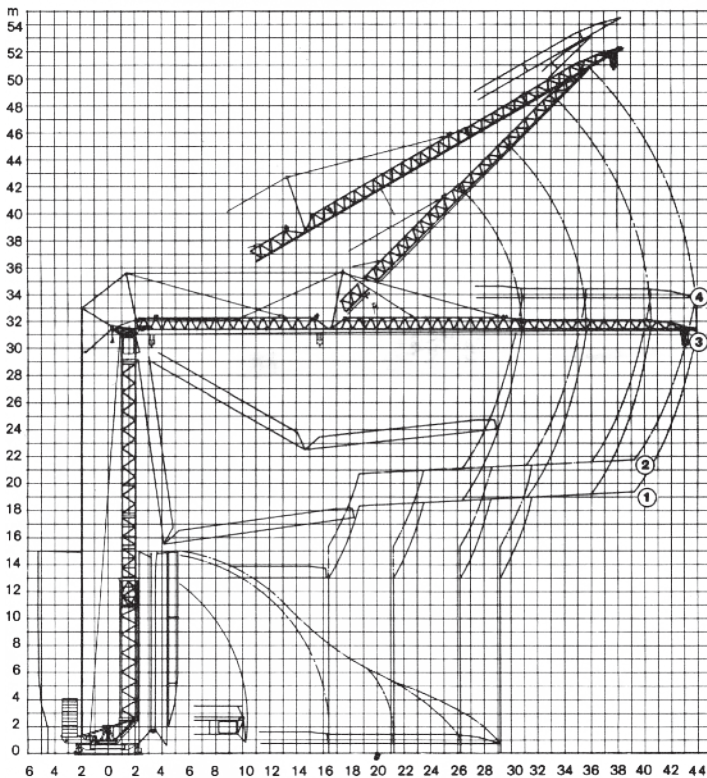
Montážní schéma



Příkony a rychlost el. motorů

	rychlost	spotřeba
	U/min. 0 ↔ 0,8 sl./min tr./min	3,0 kW
	20,0 / 40,0 m/min	1,5 / 2,2 kW

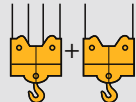
	rychlost	kg	m/min
15,6 kW 	1	3000 6000	6,5 3,25
	2	3000 6000	28,0 14,0
	3	1600 3200	53,0 26,5

přívodní kabel	jistič
99 m / 4x16 mm ² / 380 V	28 kVA